



ESCAPE



A wonderful bathing experience!

The Escape walk-in tub features our unique uni-body construction – one seamless composite fiberglass bowl with a luxurious gelcoat surface. The apron, tub deck and bowl are seamless, free of the worry of water leaks.

The superior strength and resistance to movement makes the door opening impervious to twisting and warping. All Bestbath® walk-in tubs offer a limited lifetime warranty.

Pre-installed plumbing with quick connect lines for professional installation.

The elegant, user-friendly patented door latch is constructed of stainless steel and brass components, no plastic. If adjustment should ever be necessary, it is easily made with this designer lever.

Jetted models feature the quietest whirlpool pump available, the Syllent Pump. This pump is designed with a heat recycling feature to help maintain water temperature and eliminate the need for an expensive in-line heater and additional wiring.

Stainless steel cable operated tub drain mechanism with a lever handle for easy operation.

Seat warmer for added comfort.

Optional deck extension and wall surround available to complete the installation.

Optional ozone sanitation system available.

ESCAPE

PERSPECTIVE VIEW

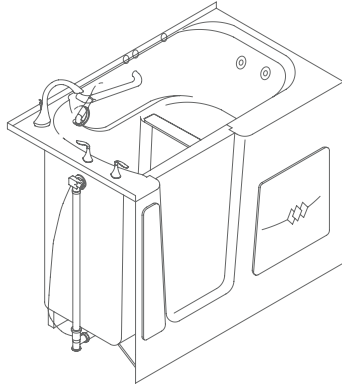

TOP VIEW

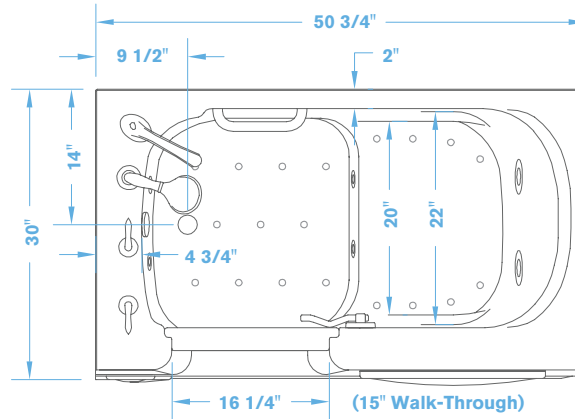

Options and accessories vary by model.

CODES

Designed and manufactured in compliance with the following standards and codes:

- I.A.P.M.O. / A.N.S.I. Z124.1.2-2005 Plastic Bathtubs and Showers
- A.S.M.E. A112.19.15-2005 & CSA B45-02 (R08) Whirlpool Bathtubs with Pressure Sealed Doors
- A.S.M.E. A112.19.7-2006 Hydromassage Bathtub Appliances
- Underwriters Laboratories 1795 & CSA C22.2 No. 218.2-93 Hydromassage Bathtub Appliances

LTOW5030 Escape Features:

- Seat warmer with keypad control
- Designed to fit in the space of your current bathtub
- Seat height is designed for ease of sitting and standing up
- Extra deep for a full body soak
- Innovative patented door handle designed for easy operation
- Reliable door seal that comes with a limited lifetime warranty
- Allows you the freedom to rehabilitate at home, or enjoy a long soak in a safe, comfortable spa-like tub
- Space under tub allows for reverse plumbing
- Optional Syllent brand jet pump: a revolutionary, ultra quiet design that helps maintain water temperature without an external heater, limiting the power requirements to just 15 Amps/110 Volt (3 year limited warranty)
- Optional (heated) Airjet system (15 Amps/110 Volt)



BESTBATH PRODUCTS ARE MADE IN THE USA and come with a limited lifetime warranty so you can relax knowing you're covered now and in the future.



bestbath.com

Toll Free 800.727.9907
 Fax 208.333.8657
 723 Garber Street
 Caldwell, ID 83605

Reorder # 076FORM2027 06/16
 Bestbath is a trademark of Best Bath System, Inc. © 2016 All rights reserved.