

POWER REQUIERMENTS: 115 VAC, 3 AMP, SINGLE PHASE
 GROUNDED RECEPTICAL, 9' POWER CORD SUPPLIED.
 20' POWER CORD OPTIONAL. SENSORS-TOUCH CONTROLS
 FLOOR MATS, WALL SWITCHES RADIO CONTROL AS SPECIFIED.

PROPRIETARY AND CONFIDENTIAL
 THE INFORMATION CONTAINED IN THIS DRAWING
 IS THE SOLE PROPERTY OF POWER ACCESS
 CORPORATION. ANY REPRODUCTION IN PART OR
 AS A WHOLE WITHOUT THE WRITTEN PERMISSION
 OF POWER ACCESS CORPORATION IS PROHIBITED.

| | | | | |
|-----------------------------|-----------------------|-----------|----------|--------------------|
| UNLESS OTHERWISE SPECIFIED: | | NAME | DATE | POWER ACCESS |
| DIMENSIONS ARE IN INCHES | | BH | 10/29/15 | |
| TOLERANCES: | FRACTIONAL ± | DRAWN | | TITLE: |
| | ANGULAR: MACH ± | CHECKED | | ARCHITECTURAL |
| | TWO PLACE DECIMAL ± | ENG APPR: | | REQUIREMENTS |
| | THREE PLACE DECIMAL ± | MFG APPR: | | SIZE DWG. NO. |
| INTERPRET GEOMETRIC | TOLERANCING PER: | G.A. | | D 4300L |
| MATERIAL | | COMMENTS: | | SCALE: 1:4 WEIGHT: |
| NEXT ASSY | USED ON | FINISH | | SHEET 1 OF 2 |
| APPLICATION | | | | |

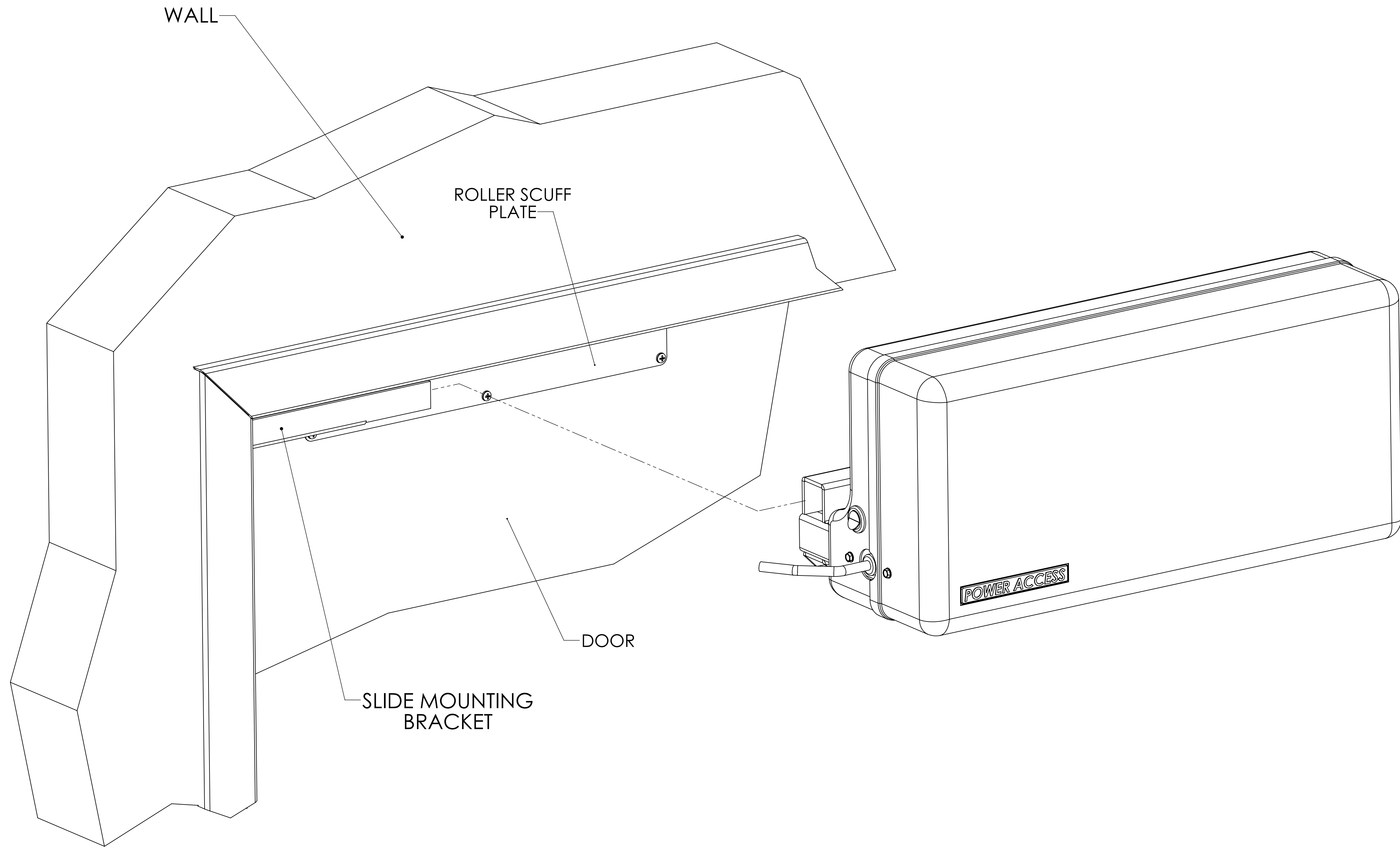

PROPRIETARY AND CONFIDENTIAL
 THE INFORMATION CONTAINED IN THIS DRAWING IS THE SOLE PROPERTY OF POWER ACCESS CORPORATION. ANY REPRODUCTION IN PART OR AS A WHOLE WITHOUT THE WRITTEN PERMISSION OF POWER ACCESS CORPORATION IS PROHIBITED.

| | | | | |
|--------------------------------------|---------|-----------|----------|------------------------------------|
| UNLESS OTHERWISE SPECIFIED: | | NAME | DATE | TITLE: POWER ACCESS |
| DIMENSIONS ARE IN INCHES | | B.H. | 10/29/15 | |
| TOLERANCES: | | DRAWN | | ARCHITECTURAL REQUIREMENTS |
| FRACTIONAL ± | | CHECKED | | |
| ANGULAR: MATCH ± | | ENG APPR: | | SIZE DWG. NO. D 4300L-1 REV |
| TWO PLACE DECIMAL ± | | MFG APPR: | | |
| THREE PLACE DECIMAL ± | | G.A. | | SCALE: 1:4 WEIGHT: SHEET 2 OF 2 |
| INTERPRET GEOMETRIC TOLERANCING PER: | | COMMENTS: | | |
| MATERIAL | | | | |
| NEXT ASSY | USED ON | FINISH | | |
| APPLICATION | | | | |