



division of Fiberglass Systems, Inc.  
 4545 Enterprise Street Boise, ID 83705  
 ph.: 800-727-9907 fax: 800-627-0929 www.best-bath.com

LPB1W

Storage: Do not Rest on the Bottom Once the Drain Fitting is Installed

Remove this block before installing

8" x 8" or 8" diam.

NOTE: The drain cut-out must be 8" diam. or 8" x 8" and back filled if it is larger to prevent flexing.

Supplied Adhesive

6" MAX.

3/4" Minimum

Adhesive: 3/4" dollops every 6" min. starting approx. 2" from cut out

Weigh down the weight plates: check that they are tight all along the shower floor with no dips or high areas.

Do not walk on bottom until adhesive has set up  
**TIP:** Also put adhesive between 2 pcs. of scrap wood to monitor cure.

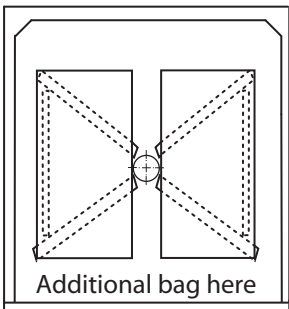
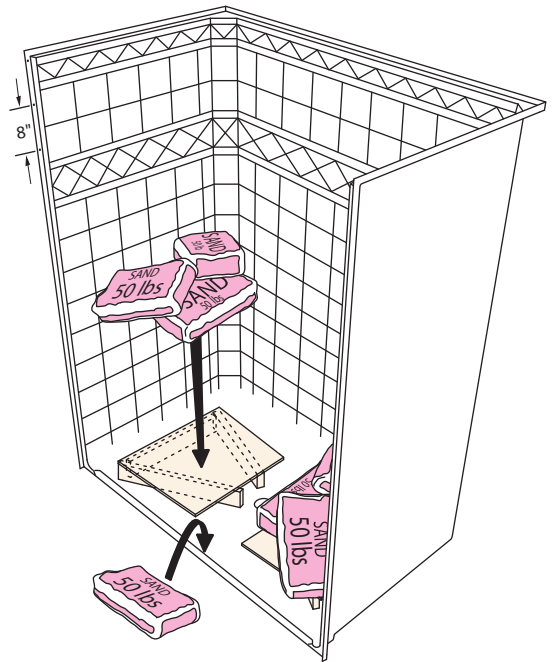

PLAN for Showers Smaller than 5'  
 All curb heights: 7 ea. 50 lb Bags.

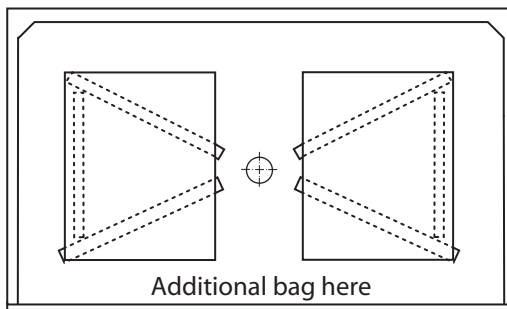

PLAN for Showers 5' and Larger  
 5/8" - 3/4" curb: 7 ea. 50 lb Bags.  
 1" - 1-1/4" curb: 13 ea. 50 lb Bags.

**ATTENTION:** Weight Plates will be sent with the First Load Only. Please keep your weight plates for use with subsequent shipments.

**SEE BACK FOR ADDITIONAL IMPORTANT INSTRUCTIONS**

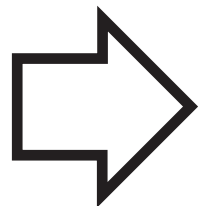



division of Fiberglass Systems, Inc.

4545 Enterprise Street Boise, ID 83705

ph.: 800-727-9907 fax: 800-627-0929 www.best-bath.com

## Installation Instructions

### Showers with Low Profile Bottoms

**The extremely low profile of this shower bottom may eliminate the need for recessing. In order to get full, permanent contact with the floor, it MUST be installed per these instructions. FAILURE TO FOLLOW THESE INSTRUCTIONS MAY RESULT IN FAILURE NOT COVERED BY WARRANTY**

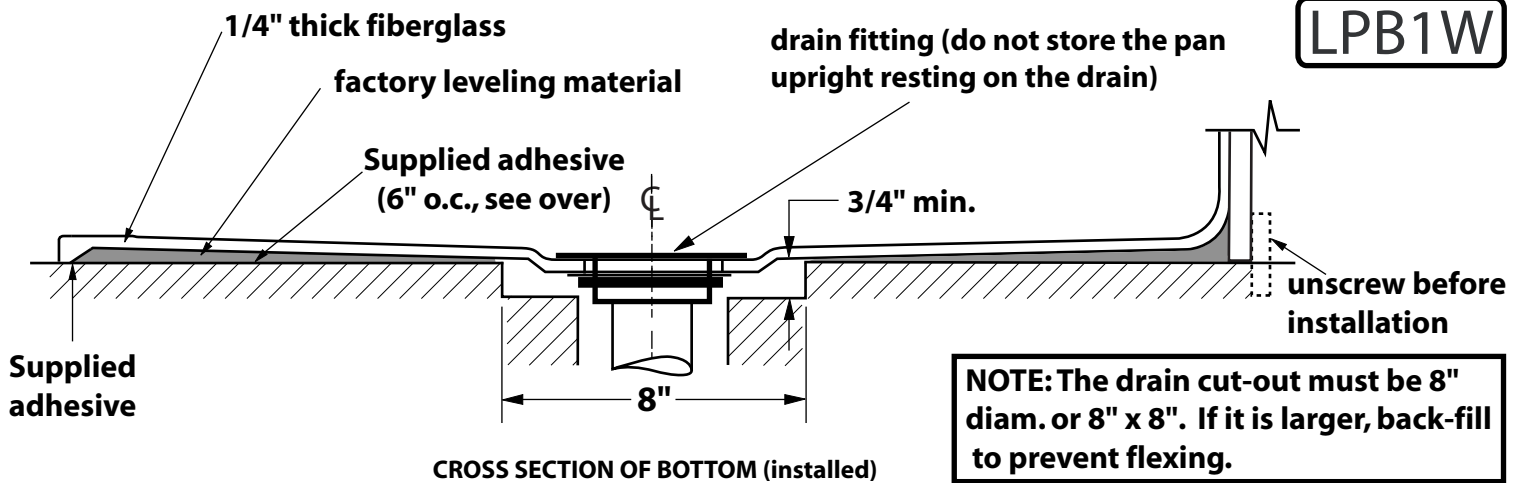

## Installation:

1. Check the stud pocket for level and correct dimensions and the drain hole in the floor for the correct distance to the studs. The floor must be level +/- 1/8 inch and swept clean.
2. The shower drain must be centered in an 8" cut-out in the floor (refer to specification or the actual shower). See drawing above.
3. Have the plumber install the drain fitting. **DO NOT** store the unit resting on the drain.
4. Prepare the drain pipe to receive the drain.
5. Clean the floor and the pan's underside. The floor may be damp but no standing water.
6. The leveling material has been scuffed up at the factory. Clean off any debris stuck to it.
7. Remove the plywood strip that is screwed to the leveling block at the back.
8. Draw a line where the curb will be.
9. Put the unit face-down in front of the pocket.
10. Apply the supplied adhesive to the floor. (See illustration on the front page) At the same time, glue some scrap wood together as a cure time sample for step 15.
11. Tip the shower into position, making sure it is positioned at the line drawn in step 8. Avoid stepping on the bottom until the adhesive has set up.
12. When level, screw through the flanges.
13. Use weight plates to brace or weigh down as shown over until snug to the shower floor.
14. Make sure the bottom has adequate drain-slope by pouring water in it or with a level.
15. Check the cure time sample from step 10 and when fully bonded or after no less than 2 hrs, remove the weight plates (more if the floor is cold).

SEE FRONT FOR ADDITIONAL  
IMPORTANT INSTRUCTIONS

